

PA AMPLIFIER

User's Manual

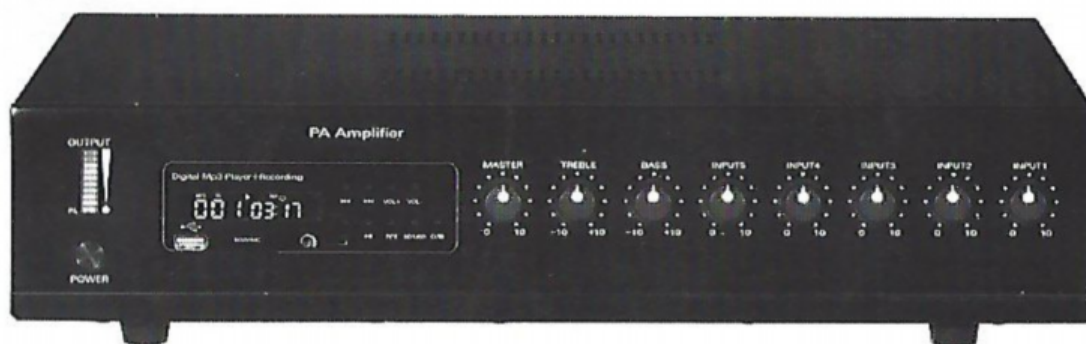

SAFETY INSTRUCTIONS



CAUTION: To reduce the risk of electrical shock, do not remove the cover (or back) .No user serviceable parts inside; refer servicing to qualified personnel.

WARNING: To reduce the risk of fire or electrical shock, do not expose this appliance to rain or moisture.



This symbol, wherever it appears, alerts you to the presence of uninsulated dangerous voltage inside the enclosure - voltage that may be sufficient to constitute a risk of shock.



This symbol, wherever it appears, alerts you to important operating and maintenance instructions in the accompanying literature. Read the manual.

DETAILED SAFETY INSTRUCTIONS:

All the safety and operation instructions should be read before the appliance is operated.

Retain Instructions:

The safety and operating instructions should be retained for future reference.

Heed Warnings:

All warnings on the appliance and in the operating instructions should be adhered to.

Follow instructions:

All operation and user instructions should be followed.

Water and Moisture:

The appliance should not be used near water (e.g. near a bathtub, washbowl, kitchen sink, laundry tub, in a wet basement, or near a swimming pool etc.)

Ventilation:

The appliance should be situated so that its location or position does not interfere with its proper ventilation. For example, the appliance should not be situated on a bed, sofa rug, or similar surface that may block the ventilation openings; or placed in a built - in installation, such as bookcase or cabinet that may impede the flow of air through the ventilation openings.

Heat:

The appliance should be situated away from heat sources such as radiators, heat registers, stoves, or other appliance (including amplifiers) that produce heat.

Power source:

The appliance should be connected to a power supply only of the type described in the operating instructions or as marked on the appliance.

Grounding or Polarization:

Precautions should be taken so that the grounding or polarization means of an appliance is not defeated.

Power-Cord Protection:

Power supply cords should be routed so that they are not likely to be walked on or pinched by items placed upon or against them, paying particular attention to cords and plugs, convenience receptacles and the point where they exit from the appliance.

Cleaning:

The appliance should be cleaned only as recommended by the manufacturer.

Non-use Periods:

The power cord of the appliance should be unplugged from the outlet when left unused for a long period of time.

Object and Liquid Entry:

Care should be taken so that objects do not fall and liquids are not spilled into the enclosure through openings.

Damage Requiring Service:

The appliance should be serviced by qualified service personnel when:

- The power supply cord or the plug has been damaged; or
- Objects have fallen, or liquid has been spilled into the appliance; or
- The appliance has been exposed to rain; or
- The appliance does not appear to operate normally or exhibits a marked change in performance; or
- The appliance has been dropped, or the enclosure damaged.

Servicing:

The user should not attempt to service the appliance beyond that is described in the Operating Instructions. All other servicing should be referred to qualified service personnel.

IMPORTANT SAFETY NOTES

- Read these instructions.
- Keep these instructions.
- Heed all warnings..
- Follow all instructions.
- Do not use this apparatus near water.
- Clean only with a damp cloth.
- Do not block any of the ventilation openings. Install in accordance with the manufacturers instructions.
- Do not defeat the safety purpose of the grounding-type plug. A grounding type plug has two blades and a third grounding prong. The third prong are provided for your safety. When the provided plug does not fit into your outlet, consult an electrician for replacement of the obsolete outlet.
- Protect the power cord from being walked on or pinched particularly at plugs, convenience receptacles, and the point where they exit from the apparatus.
- Only use attachments/accessories specified by the manufacturer.
- The apparatus should be placed in a metal rack(see INSTALLATION), and not in the following environments of cases:
 - ▲ Moist place;
 - ▲ Under direct radiation of sunlight or other strong heat radiation;
 - ▲ No air ventilation.
- Unplug this apparatus during lightning storms or when unused for long periods of time.
- Refer all servicing to qualified service personnel. Servicing is required when the apparatus has been Damaged in any way, such as power-supply cord or plug is damaged, liquid has been spilled or objects have fallen into the apparatus, the apparatus has been exposed to rain or moisture, does not operate normally, or has been dropped.
- This handbook is an integral part of the product and must accompany it when changing owner, to allow the new owner to get to know the installation, operating, and safety instructions.
- Faulty installation of the amplifier frees SHOW from all responsibility.

▲ CAUTION

To prevent the risk of fire or electrical shock, the apparatus shall not be exposed to dripping or splashing and that no objects filled with liquids, such as vases, shall be placed on the apparatus. If connecting interference takes place in source circuit, THD will be more than 10%;Don't install this equipment in a confined space such as a bookcase or similar unit.

CAUTION FOR USING POWER LINE

- ▲ You shall hold the plug firmly to avoid the pull-out of power line and risk occurring when you pull the power line out from AC outlet.
- ▲ The plug of power line for this unit should be pulled out from power outlet to cut down the power supply, when this unit isn't used for a long period.
- ▲ Don't force any matter on the power line of this system to avoid the damaging power line and don't insert the knotted power line into unit.

HANDLING THIS UNIT

Check if the power supply is being shut down, the power line is pulled out from outlet and other lines connecting this unit are also disconnected.

DON'T DISASSEMBLE THIS UNIT

Don't disassemble and repair the unit by yourself, otherwise it may induce electric shock or fires. If you can't remedy any occurred trouble according to the methods described in the list of this manual, you must call a qualified technician or consult with our company, and a forced using it may cause electric shock or fires.

CLEANING

When the unit needs a cleaning, you can blow off dust from the unit with a blower or clean with rag etc Don't use solvents such as benzol, thinner, alcohol or other fluids with very strong volatility and flammability for cleaning the unit body.

SAFETY PRECAUTIONS

1. Please read the notes preceded by the symbol ▲ **with special attention**, as they provide important safety information.
2. The power supply voltage of the amplifier has a sufficiently high value to involve the risk of electrical shock; therefore, **never install, connect, or disconnect the equipment with the power supply switched on.**
3. The metal parts of the equipment are earthed by means of the power cable. If the power socket used to supply power does not have an earth connection, call a qualified electrician who will earth the equipment by means of the terminal.
4. Make sure that the power supply cable of the equipment cannot be trodden on or crushed by objects, to ensure that the cable is not damaged.
5. To prevent the risk of electrical shock, **never open the equipment**: there are no parts inside that the user can use.
6. Make sure that no objects or liquids can get into the speaker, as this could cause a short circuit.
7. Never attempt to make any repairs that are not described in this manual. Contact your authorized service centers or highly qualified personnel when:
 - The equipment does not function (or functions in an anomalous way).
 - The power supply cable has been seriously damaged.
 - Objects or liquids have got into the equipment.
 - The equipment has been subject to heavy impact.
8. If the equipment is not to be used for long periods of time, switch it off and disconnect the power supply cable.
9. If the equipment gives off any strange odor or smoke **switch it off immediately and disconnect the power from the supply cable.**

PRECAUTIONS

- Do not obstruct the ventilation grilles of the equipment.
- Avoid having the amplifier work on overload for a long time.
- Fully tighten the screw terminals for speakers in order to ensure a safe contact.
- Do not force command parts (buttons, controls, etc.).
- When cleaning external parts, do not use thinners, spirits, or any other volatile substances.

DESCRIPTION

The amplifier has been expressly designed for transmitting announcements through all PA sound systems. They incorporate the following functions:

- 4 combination jack (XLR and 6.3mm) inputs, line/micro switchable sensitivity with excludable 24V dc phantom supply.
- 1 stereo RCA input, three stage sensitivity selectable.
- 600Ω teliliary signal(Tel. Paging) input.
- 1 "PREAMP OUT" output.
- 1 "MAIN IN" input
- 1 "MONITOR OUTPUT 1W/8Ω" slave output for monitor music signal.
- Input 1 priority on the other inputs with vocal activation.
- Input 1 priority on the other inputs, activation with contact.
- Outputs for speakers with constant impedance (4-8-16 ohm) and constant voltage (25-70-100 V).
- Treble and bass controls.
- VU-meter with LEDs.
- Protection against short-circuiting between output terminals.
- MP3 Player can play songs from MMC / SD card and USB memory.

FRONT PANEL

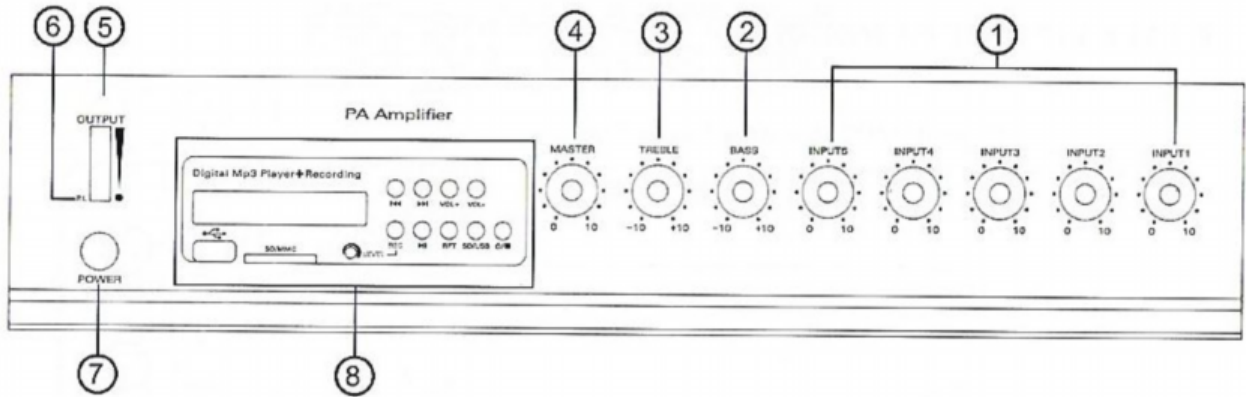

CONTROL AND FUNCTIONS

1. Input level control

These controls let you individually set the volume of the sound source that are connected to the "INPUT 1", "INPUT 2", "INPUT 3", "INPUT 4", "INPUT 5". Turning a control clockwise increases the volume of the corresponding source. We recommend to leave the control of momentarily not used inputs at their minimal setting "0".

2. Common BASS-control

When turned clockwise this control enhances the low frequency reproduction, while turning it counterclockwise attenuates the bass frequencies. If the control is set to its center position, the overall frequency response is not being altered.

3. Common TREBLE-control

When turned clockwise this control enhances the high frequency reproduction, while turning it counterclockwise attenuates the treble frequencies. If the control is set to its center position, the overall frequency response is not being altered.

4. MASTER volume control

The setting of this control determines the output level that is present at the loudspeaker OUTPUT. We recommend to generally adjust the MASTER and the input level controls at mediocre positions. Extreme setting, where the MASTER is set to maximum output and the input controls nearly set to their minimum or vice versa are not recommendable.

5. LED VU-meter instruments

This instrument shows the signal's output level. For proper operation of the amplifier correct volume setting of major importance. The first eight LED-segments on the down represent the area between -20dB and 0dB, in which the outputted level should be kept. In case the last two segments on the up are lit for a longer period of time, this means that the outgoing signal is driven into clipping, which mostly results in audible distortion. You have to adjust the volume at a lower setting.

6. Indicator

When switching the amplifier's power on, the "PL" indicator lights. When the amplifier's output overload, the "OVER LOAD" indicator lights and interrupt output. For equipment life, you have to adjust the volume at a lower setting.

7. "POWER" switch

Using the POWER switch lets you turn the main power on or off.

8. THE FRONT PANEL OF MP3-400/500

8.1 THE PICTURE OF MODULE:

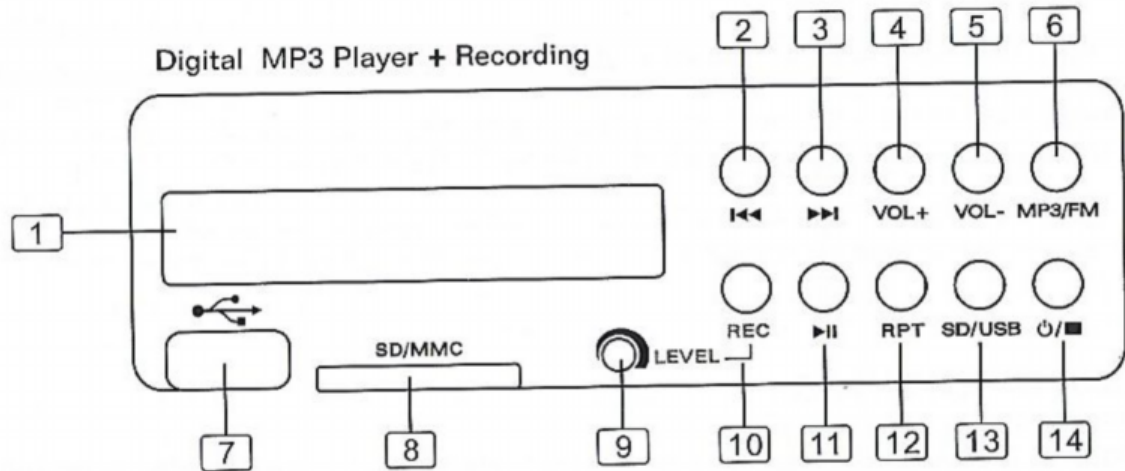

- | | |
|---|---------------------|
| 1 LCD DISPLAY | 8 SD CARD INTERFACE |
| 2 PRE | 9 REC LEVEL |
| 3 NEXT | 10 REC |
| 4/5 VOLUME | 11 PLAY/PAUSE |
| 6 Switch function between Fm and Mp3,
MP3-400 has no this function | 12 REPEAT |
| 7 USB INTERFACE | 13 USB/SD SWITCH |
| | 14 STOP / POWER |

8.2 INSTRUCTION OF OPERATION:

Please check that the module has been connected to USB or SD CARD before doing below operations.

8.2.1 POWER ON/OFF:

- Hold POWER button for about 3 seconds, then the display lights up. It means that the module is powered on;
- Hold the button for about 3 seconds again. then the display of module goes out. It means the module is powered off.
- After powered on ,the module begins to search momory device. The searching interface is as follows.

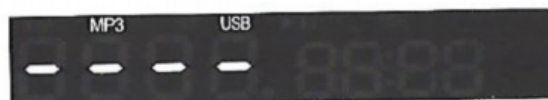

8.2.2 Play operation:

- If the module is connected to USB or SD , it can play automatically after powered on. And it plays the USB device prior.
- If there is no USB or SD connected to the model, then it plays automatically after inserting USB or SD .
- In stop or pause status,it begins to play after pressing PLAY/PAUSE button.
- The Play interface is below:



8.2.3 USB/SD switch operation:

- press USB/SD button to select USB play or SD play.

8.2.4 PAUSE operation:

- In playing status, the model pauses when press PLAY/PAUSE button.

8.2.5 Stop operation:

- The model stops when press STOP button.

8.2.6 Next DIR/Pre DIR:

- the model plays next or previous song when press NEXT or PRE button, It turns to the next folder or previous folder when hold NEXT or PRE button for about 2 seconds. If the current folder is a recording folder, then the displays.

8.2.7 Play Volume control:

- Increase or decrease the value of volume when press VOL+ or VOL- button. The factory default volume is 10.
- Volume control interface is below.



8.2.8 Repeat mode:

- press RPT button to select the below four repeat mode.
Play in sequence: no picture displays.
Repeat single: REP 1
Repeat all: REP ALL
Random play: REP

8.2.9 Record operation:

- If it has been connected to USB or SD, then the model turns to the record mode after pressing REC button.
The interface is as the below.

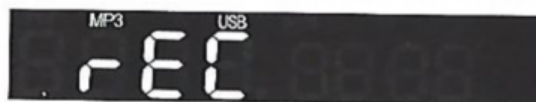

- Press USB/SD button to select USB or SD .
- Change the REC LEVEL trim pot to change the recording level
- Press REC button again. And the "REC" lights about 3~4 times, then it begins to record.
The interface is below.



- During recording, do not do other operations until press STOP button to stop.
- During recording, if "Err" appears, press STOP button to stop record.

8.2.10. FM /MP3 mode exchange (MP3-400 has no this function):

- The module default is MP3 mode, it can be exchanged to FM mode by pressing FM/MP3 button.

8.2.11. FM function operation(MP3-400 has no this function):

- Change frequency upward/downward(STEP=100KHz) by pressing PRE/NEXT button
- Search radio upward/downward automatically by holding PRE/NEXT button for about 3 seconds
- FM interface is as following:

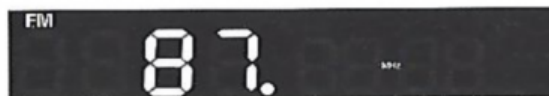

- Control FM volume by pressing VOL+/VOL- .The interface is as following:



- Factory default volume : 10

8.3 MP3-400/500 electric specifications:

8.3.1 Module input voltage requirement: DC 12V

8.3.2 Module input current requirement: 500 mA (different current consumption for different USB devices)

8.3.3 Support memory device

- Support full-speed U disc of USB1.1.
- Do not support the USB HUB.
- For the different parameters of U discs from different factories, some U disc may not be read.
- Support SD/MMC card

8.3.4 MP3 play:

Frequency response:20Hz~20KHz
1KHz, 800mV sinusoid test:

Output : 605mV
THD: <0.05%
S/N: >80dB

8.3.5 Support music type:MP3/WMA

REAR PANEL

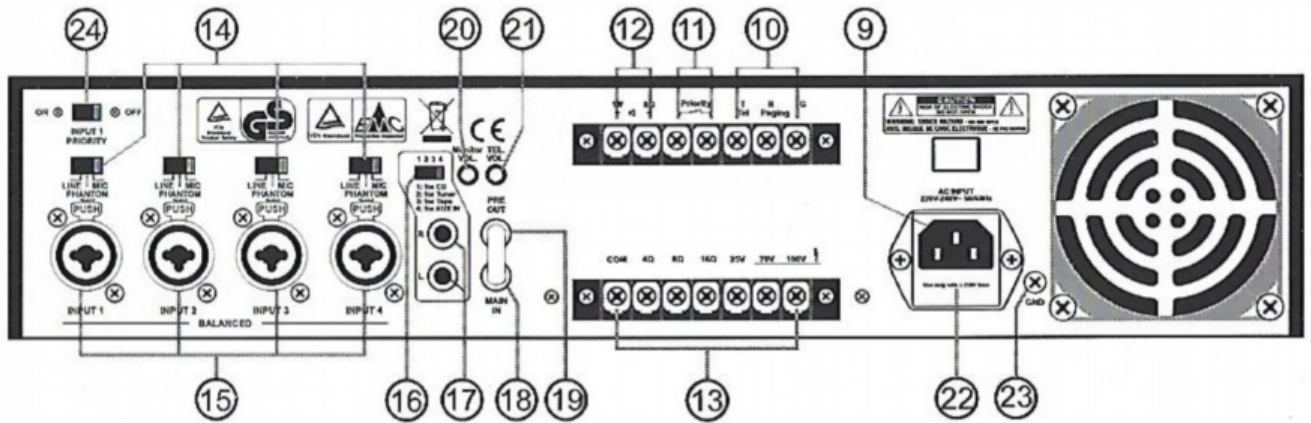

CONTROL AND FUNCTION

9. Main cord connector

This connector is meant for the connection of the supplied mains cord.

10. Input "Tel. paging"

The terminals input lets you connect to a telephone signal (600 ohms). The input features the "Voice Priority" function, which overrides all other input signals once, a telephone message is sent. If you want to have this function disabled forever, please contact a SHOW SERVICE CENTER.

11. "Priority" terminal

When short-circuiting these terminals (i.e. by means of using an electrical switch), the audio signals coming from "AUX IN", are attenuated while the signals coming from "IN2", "IN3" and "IN4" are gaining priority.

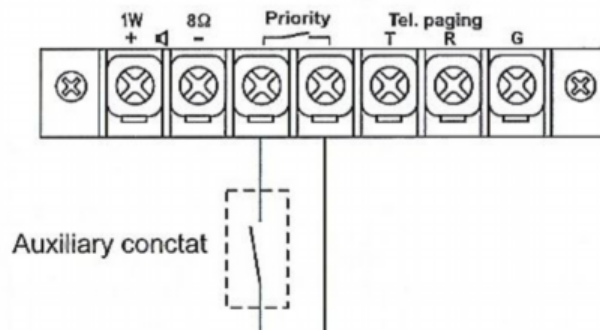

12. Output terminal for auxiliary loudspeaker

The terminal is meant for the connection of a small external loudspeaker that gets driven by an internal auxiliary power amplifier, providing a nominal output 1 watt. Only the mixed audio signal coming from "AUX IN" are included in the outputted signal. In addition, the output signal is controlled only by the Volume control of the "AUX IN", music signal level control (17).

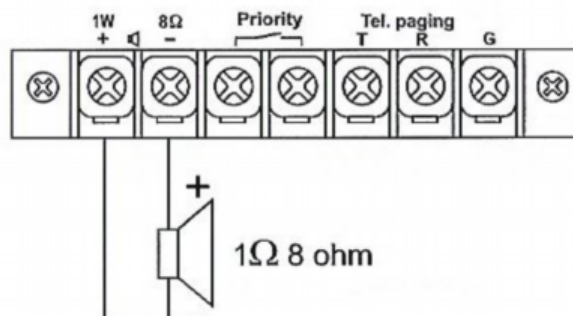

13. Output terminals

These 5 terminals allow connecting speakers.

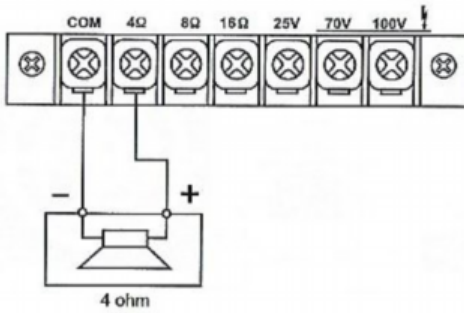

Connecting the speakers to 4 ohm output

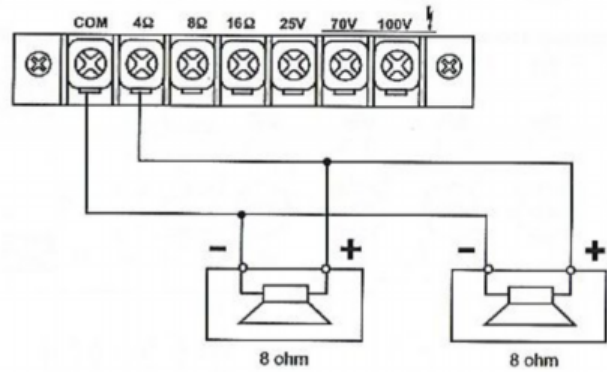

Total impedance 4 ohm

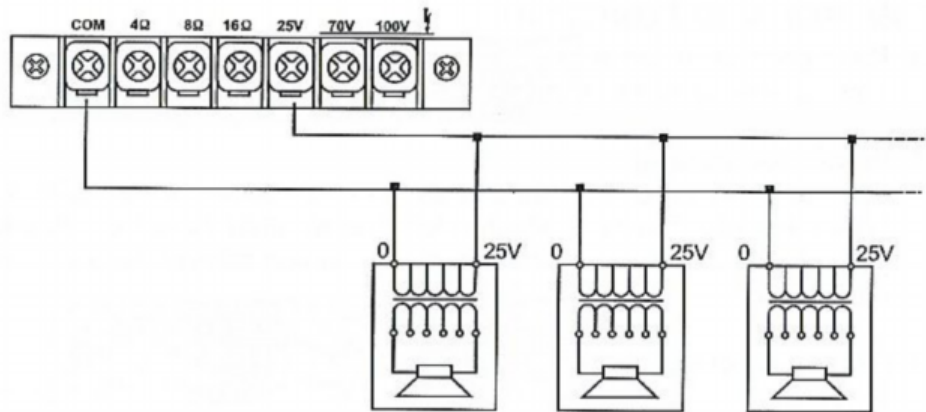

Connecting the speakers to 25V output

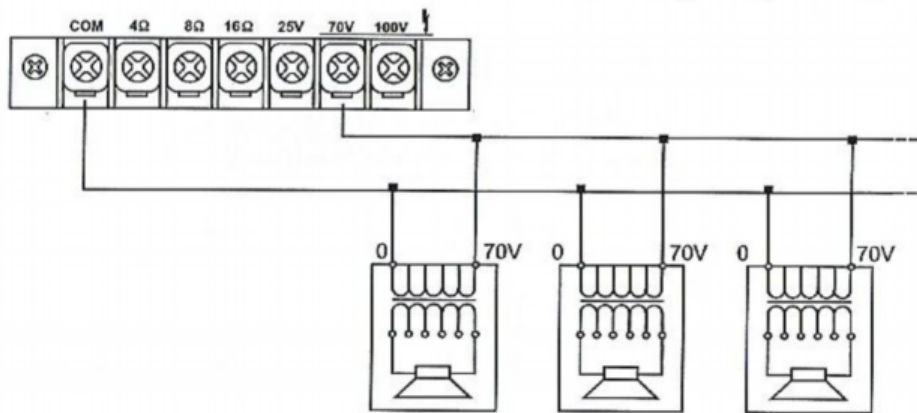

Connecting the speakers to 70V output

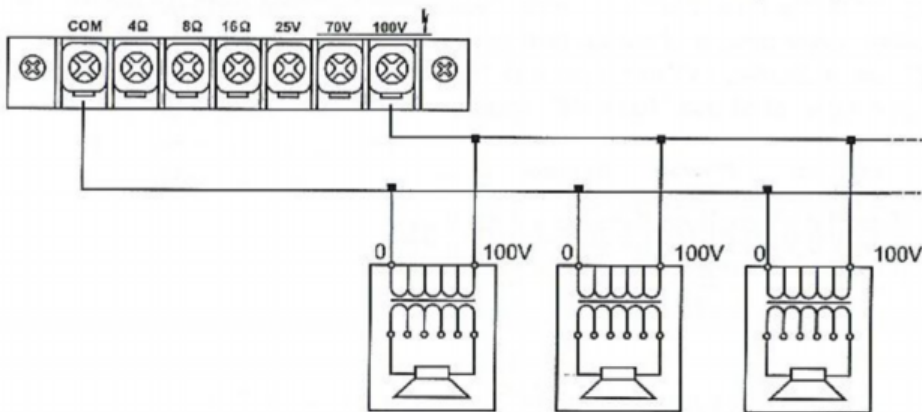

Connecting the speakers to 100V output

14. "INPUT 1", "INPUT 2", "INPUT 3" and "INPUT 4" Inputs sensitivity and XLR Phantom 24V switch

By turning these switch onto the "LINE" position the "IN1", "IN2", "IN3", "IN4" input can be connected to an audio source with high level signal output. By turning these switches onto the "MIC" position the "IN1", "IN2", "IN3", "IN4" input can be connected to a dynamic microphone with low impedance. By turning these switch onto the "24V" position connects the "24V" phantom supply on XLR of pin2 and pin3 of inputs "IN1", "IN2", "IN3", "IN4", necessary to operate condenser type microphone which require this type of external supply. It is recommended to use this switch with the general volume set on minimum.

15. "INPUT 1", "INPUT 2", "INPUT 3" and "INPUT 4" Inputs

These three balanced/unbalanced combination type jack (XLR and 6.3mm) inputs, meant for the connection of condenser type microphone that accepts 24V phantom power, dynamic microphone (30- 600 ohms) or a high level sound source (e.g. AM/FM tuner, cassette desk, CD player, etc.). In case you are using, it is necessary to use the switch (14). "Input 1" has a "Voice Priority" function that excludes all the other inputs as soon as a message is transmitted with a microphone; it is possible to exclude this function by calling a SHOW SERVICE CENTER.

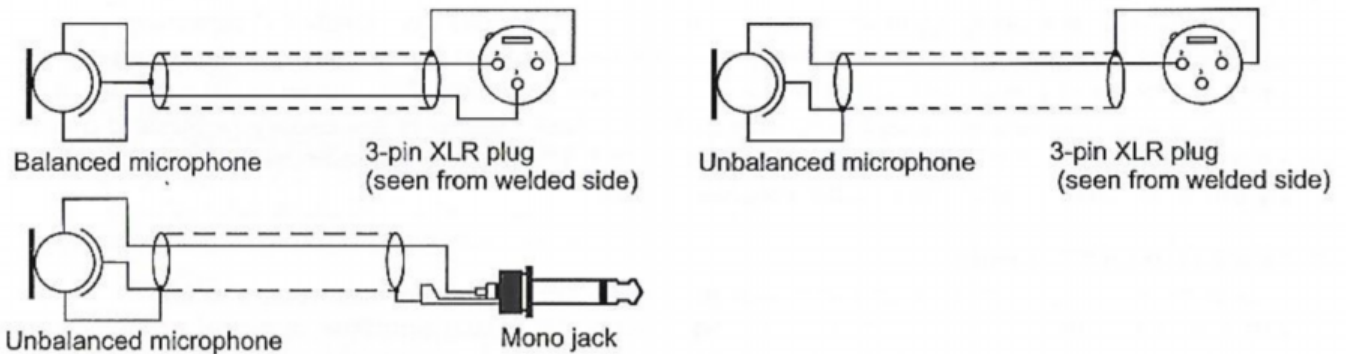

Note

Connecting unbalanced microphones to the appliance when the phantom is switched on could lead to severe damage on the microphones and is therefore not permissible. It is absolutely mandatory to perform any plugging or unplugging of microphone cables with the phantom power turned off. Also make sure, that the phantom power is turned off when utilizing microphones that are not meant to be operated with phantom power. The voltage that is present on pin2 and pin3 of the XLR-connector could lead to severe damages on the microphones. When in doubt, please consult the owner's manual of the questionable microphone or contact your dealer before you perform any connections.

16. Input sensitivity switch (AUX IN)

By turning these switch onto the "CD" position the "AUX IN" input suitable for connected to CD player signal output. By turning these switch onto the "TUNER" position the "AUX IN" input suitable for connected to AM/FM radio signal output. By turning these switch onto the "TAPE" position the "AUX IN" input suitable for connected to desktop cassette player signal output.

17. "AUX IN" inputs

The "R" and "L" sockets permit input of the right ("R") and left ("L") channels of an audio source with a high-level output signal, such as an AM/FM tuner, a cassette deck, a CD player, etc.. Use input sensitivity switch (13), suitable for difference appliances. They are able to take RCA-type coaxial connectors, and unbalanced signals.

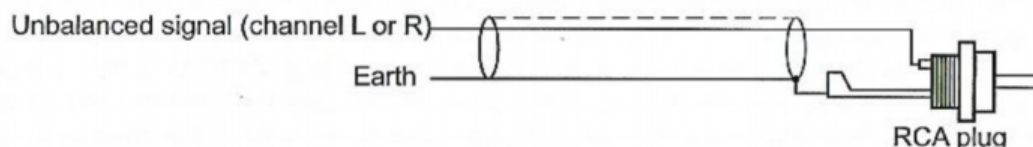

18. "MAIN IN" terminal

After removing the bridging-strip between the "PRE OUT" and the "MAIN IN" terminals you can include an external signal processor (e.g. an equalizer) in the audio-chain between the pre-amplifier and the power output stage of the power amplifier. This opportunity provides a proper solution whenever shaping or improving the audio signal is necessary (adjusting delay times, equalizing, eliminating the Larsen effect, etc.). The input is unbalanced, which is affected by the tone controls and the master volume control.

19. "PREAMP OUT" terminal

This terminal outputs the mixed audio signals of all sources that are connected to the amplifier's inputs and can be utilized to feed an external power amplifier, a signal processor (e.g. an equalizer), or any other external appliance. The unbalanced signal is affected by the individual input controls. Before using the PREAMP OUT you have to remove the bridging-strip between this binding post and the "MAIN IN" terminal (18).

20. Music signal monitor output level control

The control lets you individually set the volume of the sound source output that is connected to the "MONITOR OUTPUT 1W/8Ω" (9). Turning the control clockwise increases the volume of the corresponding source.

21. Tel. paging input level control

This control lets you set the volume of the sound source that is connected to the "Tel. Paging" (10). Turning the control clockwise increases the volume of the corresponding source. We recommend to leave the control of monetarily not used input at their minimal setting "0".

22. AC fuse

The fuse protects the alternating current supply circuit of the equipment. The fuse can only be changed in the event of a fault.

23. "GND" screw

In case the used mains outlet does not provide a ground conductor, this screw offers the possibility to ground the amplifier's metal parts. Nevertheless, you should leave this procedure to the experienced, qualified electrician.

24. Priority Switch (INPUT 1)

Set the Switch to "ON" position, the priority function will be activated, other inputs will be muted, and vice versa.

INSTALLATION

See INSTALLATION 1 & INSTALLATION 2.

INSTALLATION NOTES

At all times, the amplifier has to be operated under appropriate conditions. This includes that the operation location provided sufficient ventilation and the device is not exposed to direct sunlight or the direct radiation or reflection from any heat source. Installing the loudspeaker systems choose a location that gets not affected by extreme and / or constant vibration or other mechanical oscillation. Also make sure that the speakers are installed at locations that are free from dust and / or moisture.

▲ CAUTION

We strongly recommend that you leave the connection of the appliance to the qualified and experienced service technician who is specialized in connecting electrical and electronic equipment. Do not take the risk of Electro-shock or shock hazard. To reduce the risk of Electro-shock, all connections have to be accomplished before it is permissible to connect the amplifier to the main supply. Before connecting the appliance to the mains supply, once again make certain that all connections are carried out correctly and that no short-circuit exist. The overall sound reinforcement installation has to be in accordance to the laws, regulations, standards, and guidelines that are relevant and applicable in the country where the equipment is going to be operated.

AC POWER SUPPLY

▲ CAUTION

Before using the amplifier for the first time, make sure that the appliance's voltage is in accordance to your mains supply. Connect the amplifier only to grounded mains outlets. Connecting the amplifier to the mains supply(115/230Vac) has to be accomplished by inserting the supplied mains cord into the corresponding socket (7) and afterward plugging it into a mains outlet.

CONNECTING THE OUTPUT TERMINALS

▲ CAUTION

To avoid the risk of electrical shock, **never touch** the bare conductors leading to the output terminals of the amplifier when it is in operation. Under figures(see 16.Output terminal in CONTROLS AND FUNCTIONS), show the possible connections of the "OUTPUT" speaker terminals accessible by removing the protective cover. Bear in mind the following rules:

Constant impedance lines

- The total impedance of the speakers connected **must correspond to that selected on the Amplifier's output terminals.**
- The sum of the power capacities of the speakers must be no lower than the amplifier's power capacity.
- The length of the connecting cables must be as possible; in any case, the longer the distance to be covered and the greater must be the cross-section of the cables.

Constant voltage lines

- Each speaker must be equipped with a line transformer with an input voltage equal to that of the line (25, 70, 100V).
- The sum of the power capacities of the speakers must **not exceed the output power capacity of the amplifier.**

ADJUSTING SENSITIVITY FOR THE "VOICE PRIORITY" FUNCTION

To change the level of the signal determining activation of the "Voice Priority" function, proceed as follows:

- 1) Unscrew the 4 screws on each side and 2 screws top on side of the amplifier and take off the Cover.
- 2) Inside the amplifier, find the hole "F" on the **INPUT CARD** which permits acting on the trimmer "VR 101" on the card beneath.
- 3) Using a small screwdriver, adjust the trimmer "VR 101": by turning the control clockwise the Sensitivity increases, and the priority function will be a less intense voice signal.
- 4) Fit the bottom back onto the amplifier.

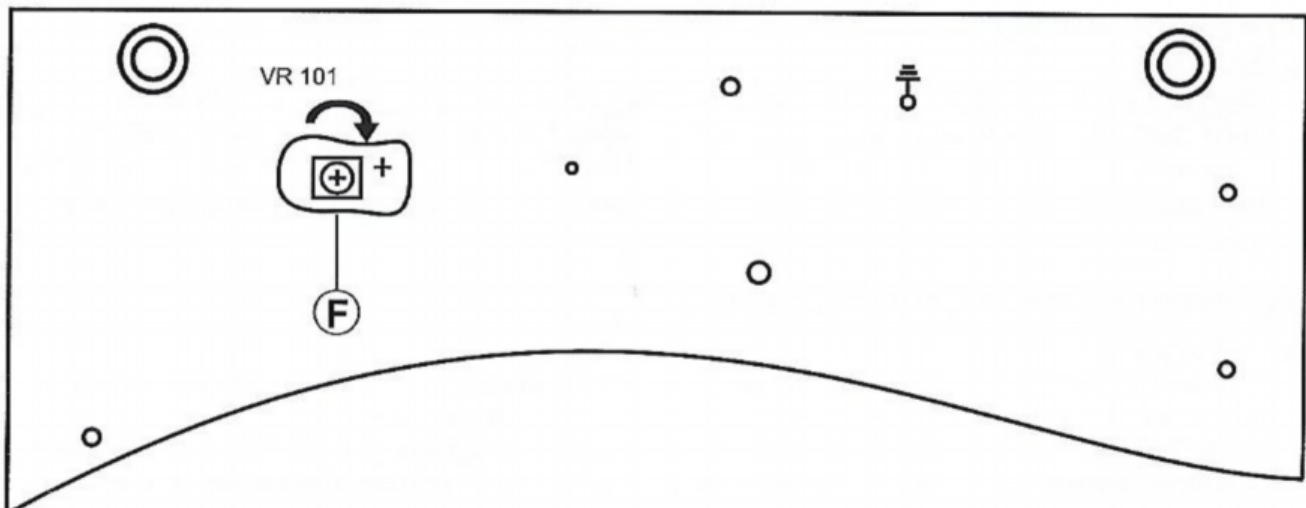

Technical data

Amplifier section

Type	240W-Mono-tabletop (240W)
Output power capacity	Nominal: 240W- maximum:300W
Frequency response	30-20,000Hz (± 3 dB)
Total harmonic distortion	$\leq 0.5\%$ (1KHz-nominal power capacity)
Signal / noise ratio	INPUT 1-4: ≥ 60 dB AUX IN: ≥ 70 dB MAIN IN: ≥ 80 dB
Inputs / sensitivity-impedance	INPUT 1-4 / XLR and 6.3mm combination socket :bal./unbal. Mic: -55/-52dB (2.3/2.7mV)-600 Ω , bal./unbal. Line: -13dB (50/100mV)-47K Ω , bal./unbal. AUX IN / stereo RCA jack / unbalanced CD: -5dB (570mV)-80K Ω TUNER: -10dB (300mV)-56K Ω TAPE: -15dB (200mV)-20K Ω AUX1: -20dB(100mV)-20k Ω MAIN IN / mono RCA jack / 0dB(1V)-10K Ω /unbalanced
Outputs for speakers / Ohms	4ohms 8ohms 16ohms
Outputs for speakers / Volts	25V-70V-100V (2.6 Ω , 20.5 Ω , 41.7 Ω) (240W)
Additional outputs / voltage-impedance	PREAMP OUT / mono RCA jack / 1V-600 Ω / unbalanced Loudspeaker / on terminal board / 1 watt-8 Ω
Tone controls	Bass ± 10 dB-100Hz Treble ± 10 dB-10KHz
Controls	7 volume controls for INPUT 1-4,AUX IN, 1W 8 Ω and Tel.Paging. 1 master volume control 1 treble control 1 bass control 5 zone paging select switch
Power supply / Consumption	115/230 Vac ($\pm 5\%$)-60/50Hz 480W (240W)
Dimensions(L \times W \times H)	435 \times 335 \times 100mm/(17.13)" \times (13.19)" \times (3.34)"

Example of possible connections

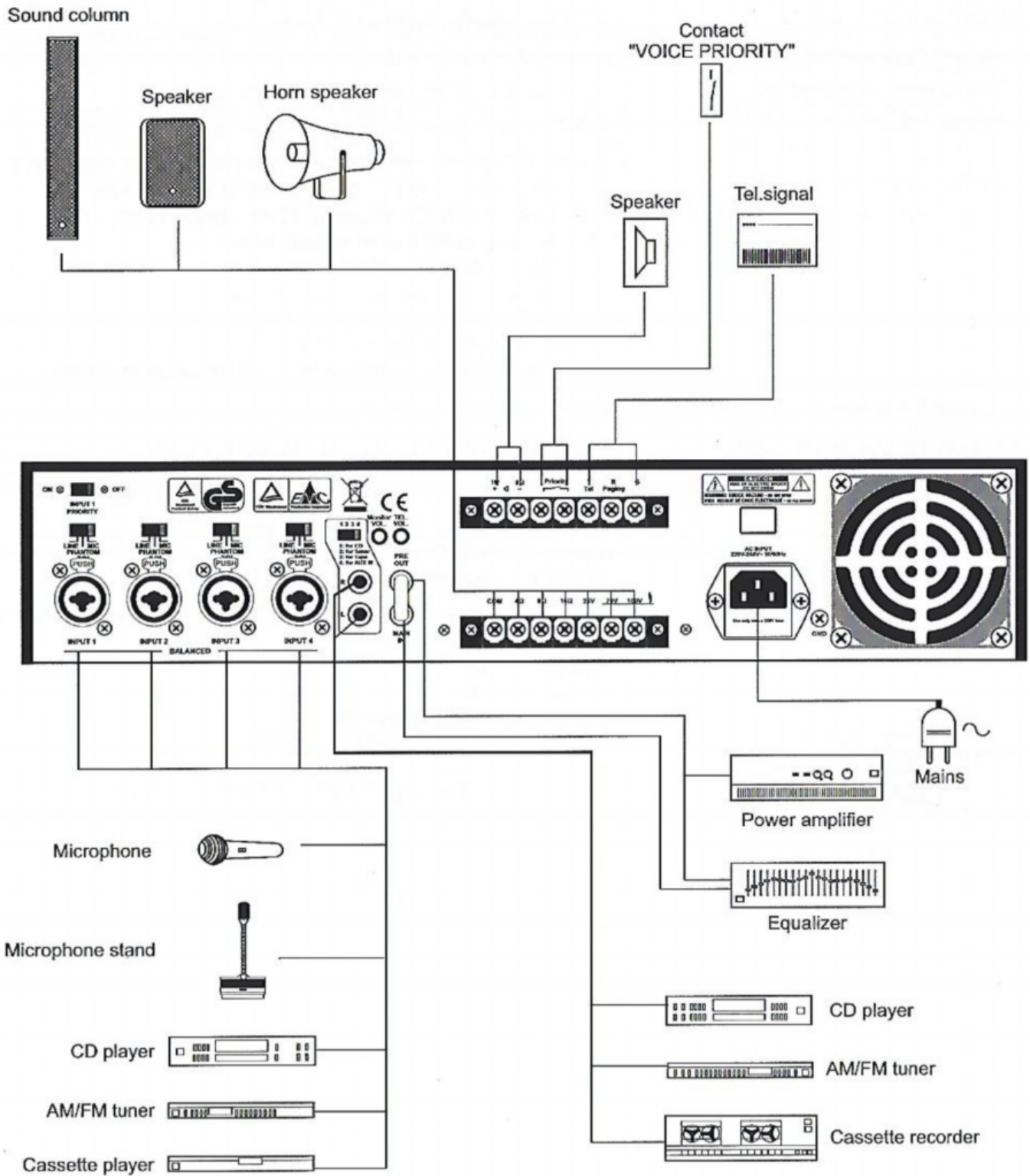

*SHOW® is a registered trademark of
SEIKAKU TECHNICAL GROUP LIMITED*

SEIKAKU TECHNICAL GROUP LIMITED
NO.1 LANE 17, SEC.2, HAN SHI WEST ROAD, TAICHUNG 40151, TAIWAN
tel: 886-4-22313737 - fax: 886-4-22346757

www.show-pa.com

seikaku@seikaku.com

NF03294-1.1